

MX700-RLPS-15-R



- Allows Operator to use 60 or 90 VAC CATV Line-Power to Feed MX700 Node Series using RG-6 Coax Drop Cable.
- Provides Flexibility to Remotely Power 12/15 VDC Optical Nodes 300' or 100 meters away.

Powered By:



Specification Sheet

Model MX700-RLPS-15-R — 12/15 VDC, 2 A, 30 W Switching Power Supply

This specification summarizes the electrical, protection, safety, mechanical, and RF characteristics provided for the MX700-RLPS-15-R switching power supply.

The Model MX700-RLPS-15-R is a compact, rugged power supply designed to reuse installed HFC coaxial infrastructure to support new optical devices at the premises. It allows the operator to make use of Cable Line Power from existing coaxial plant by extracting available CATV line power (such as 60 or 90 VAC), and converting it to low DC voltage enabling safe passage of DC power over coax drop cables such as RG-6 to the optical node. Its RF pass-through capability enables efficient deployment while maintaining dependable power delivery in demanding environments.

- **Rugged enclosure:** Die-cast waterproof housing for field reliability
- **Supports Long Distance:** Nodes can be powered over RG-6 from 300 feet (100 meters)
- **Efficient integration:** Designed for reuse of existing coaxial infrastructure, avoids high costs of electrical connections to the utility network
- **Optional RF pass-through:** Supports combined power and RF distribution applications
- **Strand or Ped mountable:** Provides flexibility for outdoor mounting to Strand or Ped
- **Galvanic Isolated DC output F-port:** Provides electrical ground isolation between HFC coaxial networks and the premises location



1. Input Characteristics



Parameter	Specification
Input voltage	Rated 46-100 VAC; variation range 40-100 VAC.
Input frequency	Rated 50/60 Hz; variation range 47-63 Hz.
Input current	1.5 A max at any input voltage with rated DC output load.
Inrush current	5 A max at 46 VAC cold start, rated load, 25°C ambient; 8 A max at 90 VAC cold start, rated load, 25°C ambient.
AC leakage current	0.15 mA max at 100 VAC input.
Power passing	17 A, each port 90 V.
Power factor	PF > 0.99 at 46 VAC input with full load; PF > 0.92 at 100 VAC input with full load.

2. Output Characteristics

Parameter	Specification
Power output	12/15 VDC, max rated load 2 A, output power 30 W.
Combined load/line regulation	Voltage 12/15 VDC; rated load 2 A; line regulation $\pm 3\%$; load regulation $\pm 5\%$.
Ripple and noise	150 mV p-p max at 12/15 VDC output.
Turn-on delay time	5 s max at rated input and maximum output load.
Rise time	40 ms max at 100 VAC input and maximum output load.
Hold-up time	5 ms minimum at 100 VAC input and maximum load.
Efficiency	Minimum 82% at 46 VAC input and full load; minimum 86% at 100 VAC input and full load.
Input protection	The power supply is protected against power line surges and abnormal conditions.
Lightning surge immunity	Meets IEC 61000-4-5, Level L-N 1 kV; no functional error at L-N 1 kV.
Electrostatic discharge (ESD)	± 8 kV air discharge, no damage; ± 4 kV contact discharge, no damage.
Temperature range test	≥ 2 hours at -40°C to $+60^{\circ}\text{C}$ with 100 VAC input; full-load on/off cycle test.
Short-circuit behavior	During a continuous short of more than 3 seconds, the power supply will lock the output; AC reset with output interruption of less than 5 seconds is required for recovery.
Overload timing	At 46 V / 60 Hz input, instantaneous maximum load current and continuous output current conditions shall not exceed 5 seconds as provided in the source specification.

3. Protection Functions

Parameter	Specification
Short-circuit protection	The power supply will automatically recover when a short-circuit fault is removed.
Over-current protection	120% minimum of full load; the power supply will automatically recover when over-current faults are removed.
Over-voltage protection	When the output voltage reaches the over-voltage protection point, the unit will enter protection mode without output and is capable of automatic recovery.

4. Safety and EMI Requirements

Parameter	Specification
Dielectric strength (Hi-Pot)	Primary to secondary, 3000 VAC, 10 mA, 60 s; primary to case, 3000 VAC, 10 mA, 60 s.
Insulation resistance	DC 500 V, 60 s aging, 100 M Ω minimum.
EMI standard	Class B rules.
Operating temperature	-40°C to $+60^{\circ}\text{C}$, full load, normal operation.
Working humidity	0%-100%, full load, normal operation.

5. Mechanical Requirements

Parameter	Specification
Enclosure	Die-cast waterproof housing.
Size	140 x 110 x 140 mm.
Weight	1.4 kg.

6. RF Parameters

Parameter	Specification
Frequency range	5-1200 MHz. A 5-1800 MHz model is indicated as available in late 2026.
Through loss (in-out)	0.5 dB min (typical 1dB) 1.7 dB max.
Isolation loss	>60 dB.
Return loss	>16 dB.
Response	±0.35 dB from nominal through loss.
Impedance	75 ohms.

7. Application Diagram

Provides a Flexible Remote Powering Option compared to the standard Power Supply



MX-700 Series Bi-directional Optical Node

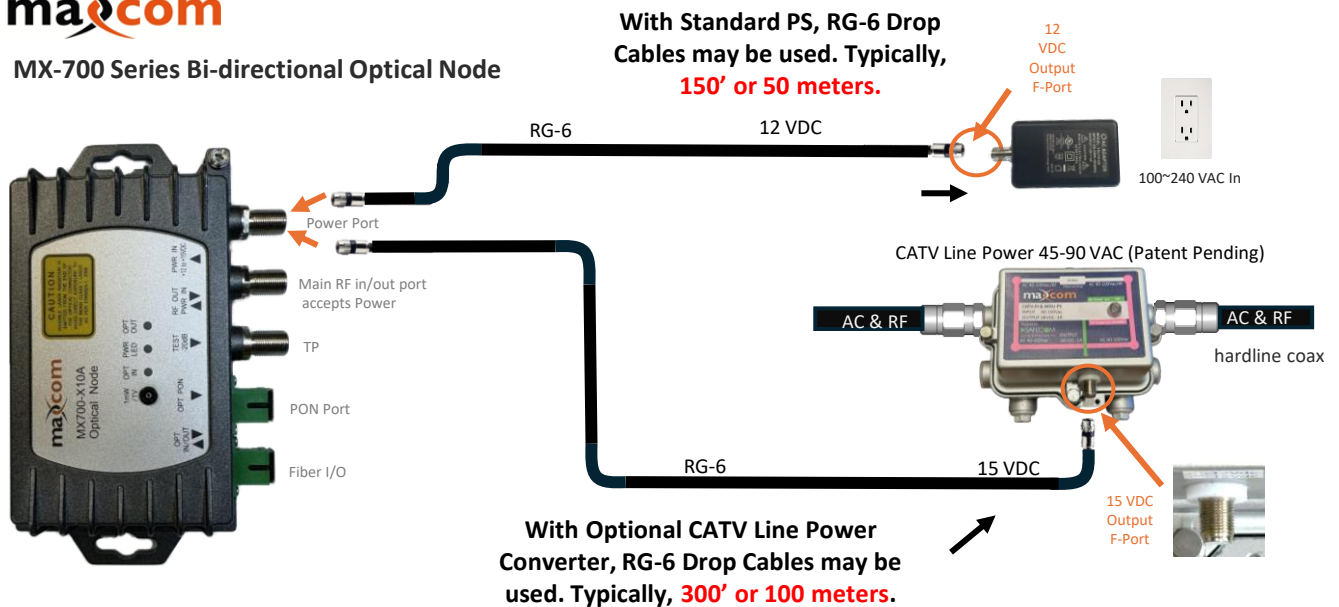

MX-700 Node Power Draw:
0.3 amps @ 15 VDC
0.375 amps @ 12 VDC

*The Maxcom MX700 series Nodes will accept an input DC Voltage range between 10~15 VDC. This allows for maximum flexibility by accounting for the voltage drop associated with long coax cable distances.

8. Fuse Configuration

•Fuse configuration across 4 ports controls AC power routing and isolation — port-level fuse slots enable flexible AC pass-through and isolation between port pairs

*When fuses are installed in all 3 slots, AC power is allowed to Enter/Exit through all 4 primary ports

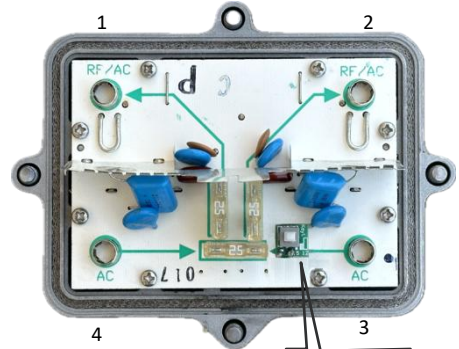
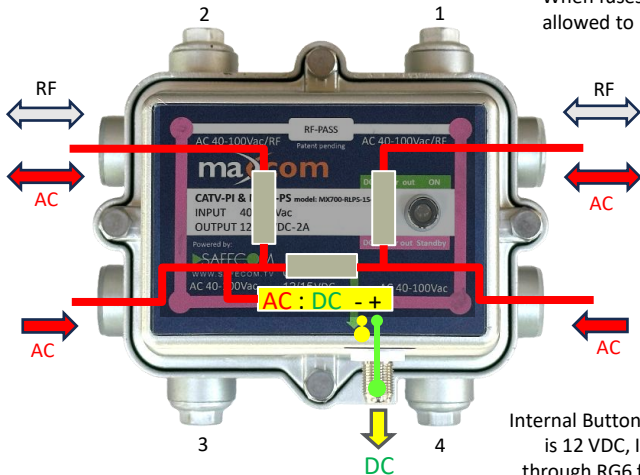

Internal Button allows user to select 12 or 15 Volts DC. Out is 12 VDC, In is 15 VDC. When feeding the MX700 node through RG6 further than 100' (30 meters), select 15 VDC

- 12VDC
- 15VDC

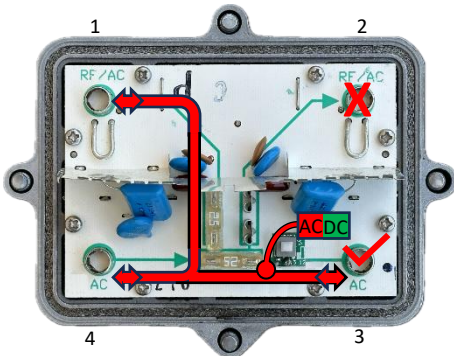

X AC Isolates Port 2

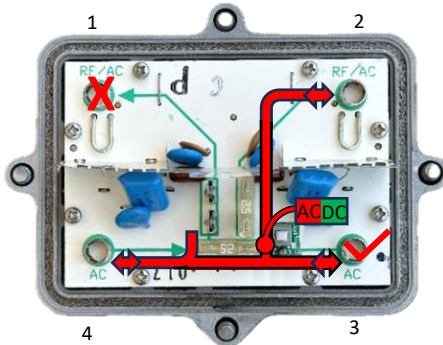

X AC Isolates Port 1

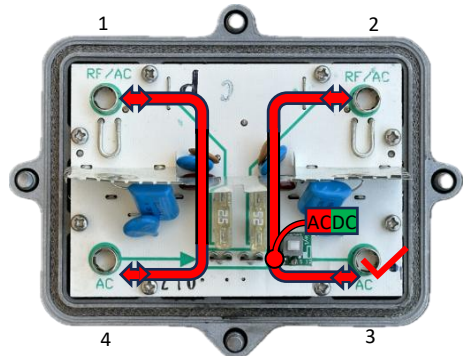

AC connection Isolates between Port 3-4



***LED on Faceplate**
Green = DC output on (Switching PS Operating)
Red = Standby (typically on for a few seconds when first powered on)
 Indicates AC input is OK
 DC output is OFF
 Causes: Turn-On Time delay, Malfunction, Overload, Short-circuit



*Port 1 and 2 allow RF to Pass through (No RF Pass on DC port, or ports 3 & 4)



*Note Port 3 will always be connected to the internal AC-DC switching PS

Product Overview

•**Model:** MX700-RLPS-15-R — a compact, rugged 12/15 VDC, 2 A, 30 W switching power supply designed for HFC (hybrid fiber-coax) network deployments

•**Core purpose:** Converts CATV line power (46–100 VAC) to low DC voltage, enabling safe DC power delivery over standard RG-6 coax drop cables to optical nodes like the MXON50 series

•**Key value proposition:** Allows Operators to reuse existing coaxial plant infrastructure instead of running new power lines to support optical devices at the premises

•**Customization:** In addition to powering Optical Nodes, This DC power supply can also power other devices such as CCTV, 5G microcell, Wi-Fi transceivers, and other outdoor devices, while saving the high cost of electrical connections to the utility network. To have your voltage requirements customized for your project, contact Maxcom and speak to our support or sales team.