

MX-ODN1.2G Bi-Directional Optical Node

Features and Options

- ✦ 1.2 GHz with up to 50 dBmV output
- ✦ Excellent Performance with Low Distortions to Maintain MER Performance
- ✦ PON Pass Through Port (Passes G & XGS PON Wavelengths)
- ✦ Flexible RF Level and Slope Control Features
- ✦ DFB Return Laser
- ✦ Multiple Diplex/Frequency splits available (Field Swapable)
- ✦ Excellent Performance Specs
- ✦ Rugged Outdoor Design with Flexible Powering



SYMBOL	PARAMETER	CONDITIONS	MIN	TYP	MAX	UNIT
General Optical and WDM						
λ	Input Wavelength Range- Forward	Standard input Range 1540~1565 Expanded input 1525~1565nm (Option E53)	1525	1550	1565	nm
λ	Upstream Wavelength Band- Return	1610	1600	1610	1620	nm
λ	PON Pass Wavelength 1 - Forward	1490	1475		1500	nm
λ	PON Pass Wavelength 2 - Forward	1577	1560		1600	nm
λ	PON Pass Wavelength Band- Return	1270 & 1310	1260		1360	nm
λ	Pass Band Insertion Loss				1.5	dB
λ	Pass to Add-Drop Crosstalk	Both directions	35			dB
λ	Forward to Return Crosstalk	Both directions	35			dB
Forward Receiver						
λ	Optical Wavelength	Extended Input Wavelengths avail 1525~1565nm	1540	1550	1565	nm
Vopt.in	Monitor Voltage	$\lambda=1550$		1		mW/V
Pin	Optical Input Power		-9	-1	3	dBm
	Optical AGC Range	Optical AGC	-8	-1	2	dBm
F	Frequency Range	*based on diplex filter selected	54	258	1218	MHz
FL	Flatness of Frequency Response	258 to 1218Hz		± 1	± 1.5	dB
S22	Output Return Loss	258 to 550MHz 550 to 1218 MHz	13 11	16 14		dB
Lo	Reference Output Level	1218MHz Adjustable with JXP Single Output *When Configured with Dual Out, subtract 3.5 dB		50	52	dBmV
	Slope	Adjustable with JXP (default 2 dB Pad installed) *Comes 10dB Pre-Slope	10	12	20	dB
	Optical Input Return Loss		45			dB
C/N	C/N	98 Pal-D channel Loading(50-550MHz OMI=3.5%, 550MHz- 860MHz low 10dB) -1dBm Opt receive	50			dB
CTB	CTB				-65	dB
CSO	CSO				-60	dB
f	Equivalent Noise Input	f=270MHz			7	pA/Hz
Return Transmitter						
λ	Optical Wavelength	*Note (1)		1610	*CWDM	nm
Wout	Optical Output Power	Example: *3mw = 4.5 dBm	2		3	mW
F	US Frequency Range	Pluggable Diplex	5		204	MHz
LRin	US RF Input Level	Reference 256QAM Signal	-6	+10	+18	dBmV
FL	Flatness of Frequency Response	f=5 to 204MHz		± 1		dB
S11	Input Return Loss	f=5 to 204MHz	14			dB
	Optical Output Return Loss		45			dB
General Parameters						
P.S. Type M	Power Supply AC Option M	AC Input Range (≤ 20 watts Consumption)	100		240	V
P.S. Type C	Power Supply AC Option C	AC Input Range (≤ 20 watts Consumption)	40		90	V
P.S. Type D	Power supply DC option D	DC Input Range	20		50	V
I _{tot}	Total Current Consumption (DC)	2 amps @ 50 VDC 2.5 amps @ 20 VDC	2a		2.5a	Amps
T _{mb}	Operating Temperature	Humidity 5% to 95%, none condensing	-20		+55	°C
Dim	Dimensions	(L×W×H)	27 x 20.3 x 12.2			cm
			10.5" x 8" x 4.8"			in

Note (1): Standard 1610nm, CWDM wavelengths avail, user selectable wavelength option Not all options available with PON Port

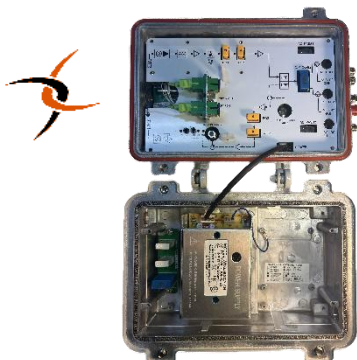

- ✦ **Flexible Powering Options**
- ✦ **Interchangeable Pads for Simple Level and Slope Control**
- ✦ **Field Changeable Diplex Filter Module**
- ✦ **Configurable for 1 or 2 Outputs**

www.maxcomcorp.com

maxcom

Interior Illustration

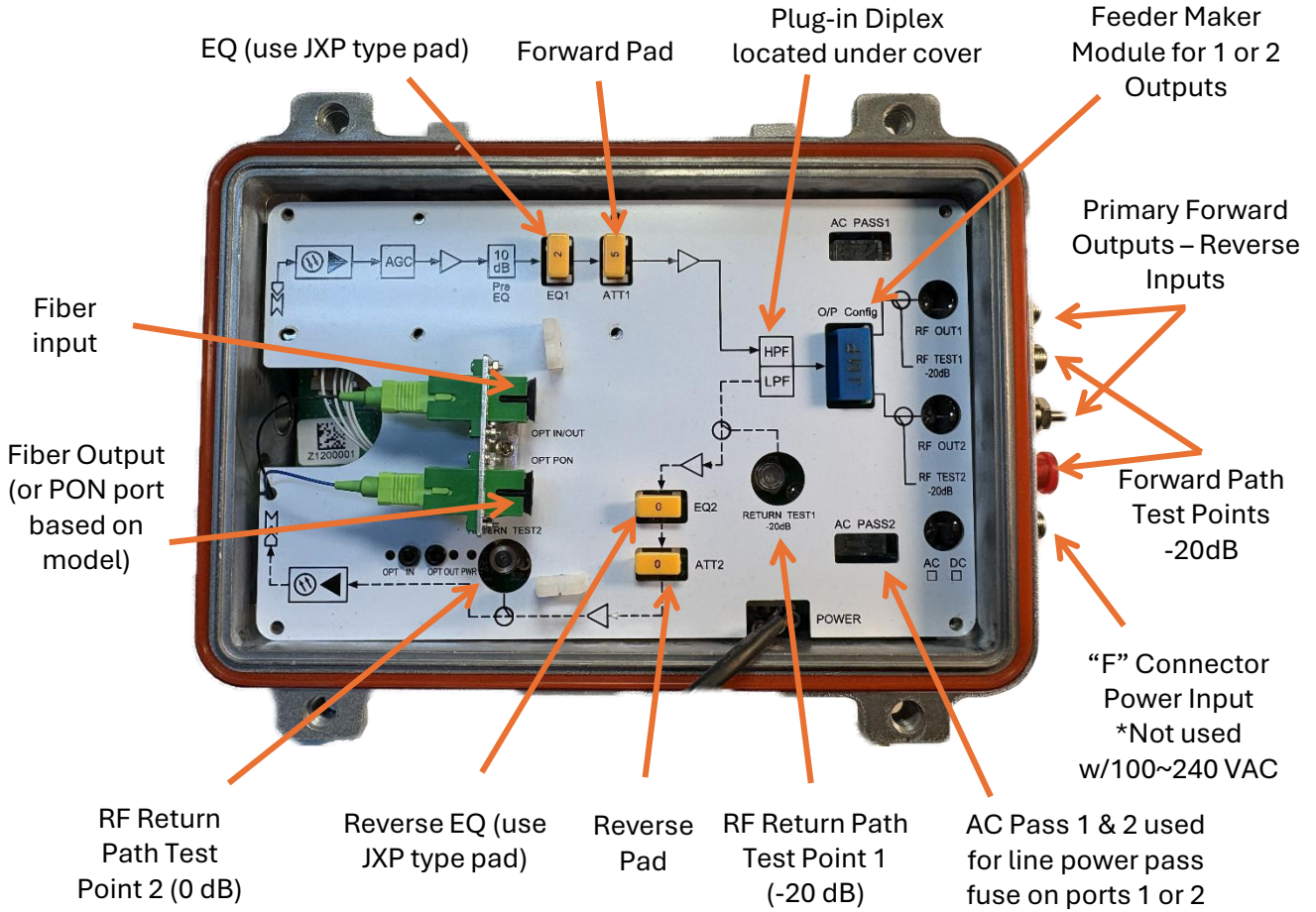

Block Diagram

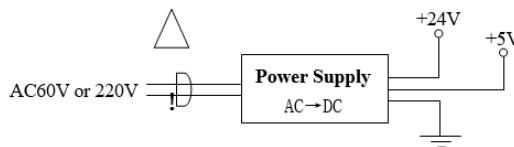
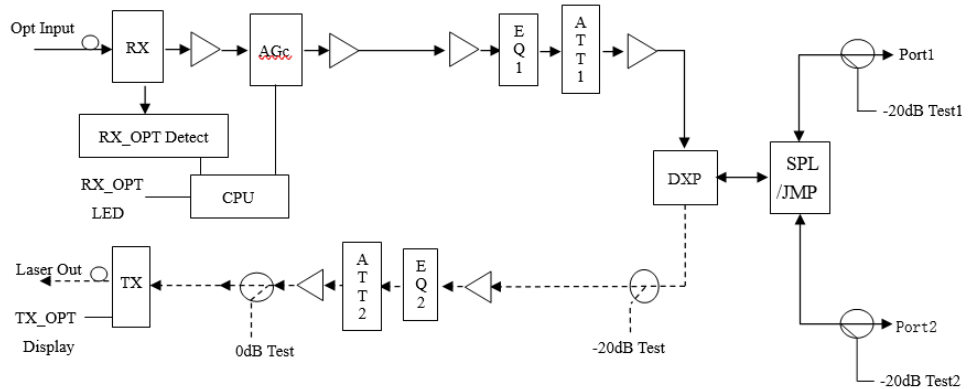

INSTALLER GUIDE:



OPTICAL, RF & POWER CONNECTIONS

1. The MX-ODN1.2 offers versatile power options and may be ordered with 3 different power supply types. Standard CATV Line-Power 40~90VAC may be connected using the available F-Ports. A fuse bar may be used to direct power through the desired ports. Main Utility Power 100~240VAC using a standard utility cord and plug, or with a 20~50 VDC Power Supply. See ordering matrix to select the appropriate power supply for your application.
2. Always follow good engineering and safety practices by making sure the unit is grounded and powered down when installing new power connections.
3. The MX-ODN1.2 Nodes RF connectors use KS-type connectors for both RF and power ports. The Seizure Screws use a Phillips-head conductor screws. When connecting with a KS-type connector, make sure the stinger length is exactly 1.0 inch (25mm). Note that the node has a feeder maker that allows the user to configure the node for Single or Dual RF outputs.
4. The adjustment plug-ins, status indicator LEDs, RF & DC test points (TPs) for the MX-ODN1.2 can be found under when opening the lid, which uses a size #5 Allen Tool or Wrench.
5. When powered on, the DC POWER ON LED of the MX-ODN1.2 will light up. Since the MX-ODN1.2 functions as an HFC node with the upstream transmitter always active, the LASER ON LED will also turn on immediately upon powering. *Note, the LASER ON LED will not be lit if equipped with Burst Mode option w/ no US carrier present.
6. Use the grounding screw on the MX-ODN1.2 to connect the chassis to a physical earth (ground).
7. The MX-ODN1.2 is equipped with an internal WDM optical filter, enabling single fiber operation for RFoG functionality. The receiver accepts downstream wavelengths ranging from 1540 to 1565 nm, while the return optical transmitter functions at 1610 nm. The unit also features a PON port compatible with passing G-PON (1310 & 1490 nm) and XGS PON (1270 & 1577 nm) wavelengths.
8. The suggested optical input level for the MX-ODN1.2 ranges from -8 dBm to +2 dBm. Utilize an optical power meter at the suitable downstream wavelength to ensure the optical level on the incoming fiber is within this range.
9. Ensure that the optical cable connector matches correctly (e.g., SC/APC to SC/APC). After cleaning all optical connectors, connect the optical fiber(s) to the OPT IN/OUT port on the ONU.
10. An additional feature is provided for users without an optical power meter. This allows the user to assess the optical input power using a digital multimeter. If the optical input power is within the acceptable range, the OPT IN LED on the photo diode will illuminate. Once the optical fiber is connected to the ONU, the OPT IN TP 1 mW/1 VDC test point (TP) on the photo diode can be utilized to measure the optical input detected by the ONU's forward receiver. Use a digital multimeter set to DC voltage and measure between the DC TP and the grounding screw. For instance, +0.794VDC = 0.794 mW, or +1VDC = 1 mW
11. The F-ports labeled "RF" serves as the bi-directional RF input and output ports for the MX-ODN1.2 optical node.
12. When the external forward TP's are not in use, please cap these -20 dB TPs with a watertight cover or 75-ohm terminator.
13. When measuring RF input/output levels using the -20 dB TP, ensure that the RF port is terminated to 75 ohms. Note that levels from the -20 dB TP will be 20 dB lower than those at the RF port.

*Continued next page



FORWARD SETUP GUIDELINES:



1. The MX-ODN1.2 incorporates JXP attenuator pads for controlling output/input levels (both forward and reverse) and for adjusting the forward tilt (slope) in the forward equalizer plug-in, enhancing flexibility.
2. When setting up the forward path, ensure that the forward optical input level to the MX-ODN1.2 is within the specified range as outlined in the OPTICAL, RF & POWER CONNECTIONS section on previous page. An optical input exceeding +2 dBm may lead to receiver overload, while an input below -8 dBm results in loss of AGC tracking, leading to suboptimal RF output, which decreases by an additional 2 dB for every 1 dB decrease in optical input. The optimal performance is achieved at an optical input level of -1 dBm.
3. The RF output level of 50 dBmV at 1.2 GHz is available only when the optical input is within the AGC range and the OMI is $\geq 3.5\%$ on the downstream optical signal. Outside the -8 to +2 dBm optical AGC range, the output will drop by an additional 2 dB for every 1 dB reduction in optical input.
4. To account for RF cable losses, a JXP attenuator pad can be inserted into the forward equalizer JXP slot. This node comes Pre-Sloped internally at 10dB between 258~1218MHz. For example, since this node comes with 10 dB of equalization, adding a 5 JXP pad (in the Forward Equalizer Slot) will create a slope of 15 ± 2 dB on the RF output of the MX-ODN1.2 from 258~1218 MHz. The forward slope (tilt) can be adjusted by changing the forward equalizer plug-in value as desired. Only use a JXP pad (attenuator) in the forward equalizer plug-in.
5. Attach a signal level meter to the RF OUT port to assess the RF output from the MX-ODN1.2. The forward output -20 dB test point can also be utilized to measure the RF output. If using the -20 dB test point, the main output must be terminated or connected to plant, otherwise the test point reading will be in-accurate.*NOTE: RF levels referenced in this manual may pertain to analog channel levels, unless specified otherwise. For digital channels, assume a level 6 dB lower than that of analog channels. *Note that when the feeder maker is configured for dual outputs using the included plug-in splitter, RF levels will be approximately 3.5 dB less.
6. If the output level is not within the desired range, the forward pad plug-in can be replaced to modify the output of the MX-ODN1.2. The forward pad plug-in accommodates a JXP attenuator pad.
7. Confirm that the RF output levels from the MX-ODN1.2 align with expectations.

REVERSE SETUP GUIDELINES:

1. For the reverse path setup, ensure that the reverse RF input level to the MX-ODN1.2 is within acceptable limits to the ONU. There is one -20 dB Return test point and one 0dB Return test point on the node module. Return TP#1 allows you to measure the upstream RF signal arriving at the node. Return TP#2 allows you the measure the upstream signal after the internal amplification (Note in the default setting with 0dB JXP in the ATT2 and EQ2 slots, then TP#2 will be equal to the RF signal input), and allows the user to adjust the upstream signal strength, and balance the flatness using the EQ2 (use a standard JXP pad in the EQ slot to achieve a flat signal response on the return spectrum).
2. The upstream transmitter in the MX-ODN1.2 operates as a continuous ON laser transmitter and remains active at all times. The OPT OUT LED on the laser diode indicates the status of the laser transmitter, which will illuminate when the MX-ODN1.2 is powered on, regardless of the upstream RF input.
3. Verify that the upstream RF input is within the specified frequency and input level range. The upstream RF input for the MX-ODN1.2 is +5 to +20 dBmV per channel (digital channel level) for 42/54 MHz units and +2 to +18 dBmV per channel (digital channel level) for 85/102 MHz units. These levels assume that a 42/54 MHz split unit has 4 equally loaded channels in the upstream band, while the 85/102 MHz split has 8 equally loaded channels. If employing a different number of channels, adjust for total RF power accordingly. The combined total RF input level to the MX-ODN1.2 (for all channels) should not exceed 27 dBmV (digital channel level) to avoid potential laser clipping and saturation. Use the following formula to calculate total RF power: Total RF power = RF power per channel + $[10 \cdot \log(\# \text{ of channels})]$.
4. It is advisable to document both the input and output levels for the node in both upstream and downstream for future reference.



*All product specifications and data are subject to change without notice to enhance reliability, function, design, or other attributes.

www.maxcomcorp.com

Ordering information

MX-ODN1.2



Maxcom High Output Outdoor Optical Node Modeling Matrix

Maxcom ODN Optical Node Series	Fiber Port Configuration	Sub Split Modular Diplex	Optical Power of Return Laser	Return Transmitter Wavelength	Powering	Power Adaptor (Plug Type)				
MX-ODN1.2	X	XX ^①	X	XXXX ^②	X	XX				
 S "S" Single Fiber I/O, (Bi-Directional Forward and Return over Single Fiber, No PON Port) D "D" Dual Fiber I/O, (One Fiber for Forward, Second Fiber for Return, No PON Port) P "P" One Fiber I/O, Second Fiber Port for PON (Passes GPON & XGS-PON Wavelengths) <small>*1270nm & 1577nm, and 1310 & 1490nm</small>	45	42/54	3	3 dBm	1310	1310nm	C	40-90 VAC (CATV Line Power)	00	None (Default if ordering "C" CATV Line Power)
	57	55/70	4	4.5 dBm	1470	1470nm	M	100-240 VAC (Mains Utility Power)	01	North America
	68	65/85			1490	1490nm	D	20-50 VDC (DC Power)	02	E.U.
	81	85/102			1510	1510nm				
	22	204/258			1530	1530nm				
					1550	1550nm				
					1570	1570nm				
				1590	1590nm					
				1610	1610nm					

Example: **MX-ODN1.2-P-22-4-1610-C-00**

Outdoor Node, One Fiber I/O, Second Fiber Port for PON, w/ 204/258 subsplit, 4.5 dBm output laser power, 1610nm Return Transmitter, 40-90VAC Range CATV Line Power

Note:① sub-split diplex filter is field swappable.

Note:② Not all TX wavelengths are available on the "P" model due to conflict of PON wavelengths ("P" Model comes standard with 1610nm)

General Note: All versions come standard with SC/APC optical connectors, and include the Power Supply

- ✦ The MX-ODN1.2 Series Optical Nodes are Designed for Maximum Versatility and Performance. They are ideal for Indoor or Outdoor Fiber-to-the-Building and MDU applications. The high RF output, available Return DFB Laser Options, Gain and Slope control, Pluggable Diplex Filter, and Powering offer the Technician the Flexibility Needed for Individual Customer Situations and Installations.
- ✦ Maxcom provides professional optical solutions. Our engineers can help you with any project design and equipment needs. We offer an outstanding warranty on all of our products, along with strong technical support staff.
- ✦ Please feel free to contact Maxcom with any questions
- ✦ 1-877-330-5333 or 209-339-2333
- ✦ www.maxcomcorp.com



*All product, product specifications and data are subject to change without notice to improve reliability, function, design or otherwise.

Maxcom Confidential and Proprietary