



The Maxcom MX700-3 series ONU's are ideal for use in fiber to the home and fiber to the business RFoG applications. An excellent platform for delivering upstream and downstream DOCSIS, voice, video, and high-speed data service over FTTX applications. They are designed compliant to industry standards to terminate an RF over Glass (RFoG) communications network. The standard model uses a single fiber and receives downstream signals at 1550nm and uses a 1610nm isolated DFB return transmitter. Built with maximum toughness and the best warranty in its class.

The MX700 series may be ordered with various features and options. Single and Dual fiber models are available, and PON pass through ports are optional. Various optical wavelengths may be ordered for the forward and return optics. Contact a Maxcom Rep to learn about these and other options.

ONU Features

1. CATV Bi-directional single fiber port
2. Burst mode operation – Isolated DFB Lasers for improved stability to reduce OBI
3. Superior proven technologies for both RF amplification and optical components
4. AGC for consistent RF level outputs (20 dBmV and 36 dBmV output versions available)
5. Automatic Optical Control is designed to reduce return noise effectively.
6. Low power consumption, compact in size, built tough, with Max reliability
7. Follows SCTE 174 standards

www.maxcomcorp.com

1.209.339.2333 or 1.877.330.5333



Specifications

PARAMETER	CONDITIONS	MIN	TYP	MAX	UNIT
Forward Receiver					
Optical Wavelength	*Extended/custom wavelength options avail. (Example 1525~1565nm)	1540	1550	1565	nm
Monitor Voltage	$\lambda=1550$		1		V/mW
Optical Input Power	Optical AGC / Continuous	-6	-1	+2	dBm
Bandwidth	1.2 GHz	54*		1220	MHz
Flatness of Frequency Response	f=54 to 1002MHz		± 0.75	± 1	dB
Output Return Loss		14	16		dB
Standard Reference Output Level w/AGC when optical input is between -6 and +2 dBm *(may be ordered w/ 20 or 36dBmV output versions)	(Note 1) @ 3.5%/2.7% OMI per Ch. (Analog / Digital)		*20		dBmV
Slope	5dB slope ± 2 dB		5		dB
Optical Input Return Losses		45			dB
C/N	(-1dBm optical input, 3.5% OMI/ch, 79ch NTSC, Digital ch above 550MHz at -6dB offset)	50			dB
CTB				-65	dB
CSO				-60	dB
Equivalent Noise Input	f=55MHz			7	pA/Hz
Return Transmitter					
Optical Wavelength	1610nm Standard. Additional wavelengths avail.	1600	1610	1620	nm
Optical Output Power	w/ 2mW Isolated DFB laser	2	3	4	dBm
Dynamic Input Range	NPR ≥ 38		20		
RF Input Level	Typical 20-40	20	30	40	dBmV
Bandwidth	Expanded options available, *see ordering matrix	5	54	204*	MHz
Flatness of Frequency Response	f=5 to 42MHz		± 0.75	± 1	dB
Input Return Loss	f=5 to 42MHz	14	16		dB
Optical Output Return Loss		45			dB
Optical Laser turn ON Level	Follows SCTE 174 (Note 2)	13	15		dBmV
Optical Laser turn OFF	Follows SCTE 174 (Note 2)		-5		dBmV
Laser Rise Time to 90% optical ON				1.3	μ s
Laser Fall Time for optical to 10%				1.6	μ s
General Parameters					
Total Current Consumption (DC)	W/12VDC Power Adapter		4.2		W
Temperature Range in Fahrenheit degrees	-40°C to +65°C	-40		+149	°F
Dimensions (including connectors)	Width x Height x Depth	6.77"	4.25"	1.65"	Inch

Note 1: Power output is measured at 1002MHz.

Note 2: Burst mode parameter may be adjustable according to customer's request

* See Ordering Matrix next page



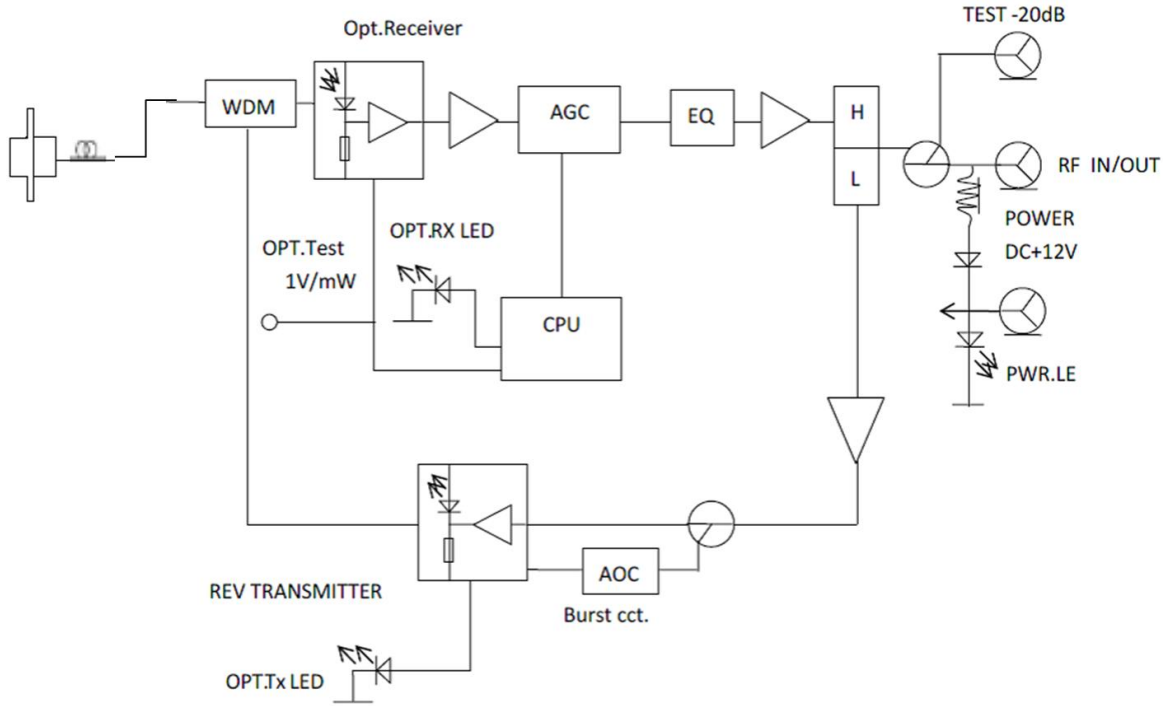

Functional Diagram of MX700-3 series ONU

Maxcom R-ONU Mini Optical Node Modeling Matrix

Maxcom Mini Optical Node Series		Forward RF Output Level	Return RF Input Level	Laser Type	Tx. Optical Power	Optical Connector	Transmitter wavelength	Sub Split	Power Adaptor	Forward Frequency	Options			
MX700-XXX (A=AGC on forward path, C=Burst mode return laser)		XX ^①	XX ^②	X	X	XX	XXXX	XX ^③	XX	XX	XXX			
MX700-2A	Dual fiber I/O, continuous "On" return path (No burst), AGC on the forward path	20	20dBmV	20	20dBmV	D DFB	2	2mW	SA SC/APC	1310 1310nm	45 42/54	01 North America	1.2G 1220MHz	- Standard 15.40-15.65nm
		36	36dBmV	30	30dBmV	I Isolated DFB	3	3mW		1470 1470nm	57 55/70	02 E.U.	2.6G 2600MHz	E 53 Extended input RX wavelength 15.25-15.65nm
MX700-3A	Single fiber I/O, continuous "On" return path (No burst), AGC on the forward path						1490 1490nm	68 65/85					3.0G 3000MHz	
MX700-2AC	Dual fiber I/O, burst mode on the return, AGC on the forward path						1510 1510nm	81 85/102						
MX700-3AC	Single fiber I/O, burst on the return, AGC on the forward path						1530 1530nm	22 204/258						
MX700-X10AC	One fiber I/O, a 2nd fiber port for GPON & XG(S)PON, burst on the return, AGC on the forward path						1550 1550nm							
MX700-X10A	One fiber I/O, a 2nd fiber port for GPON & XG(S)PON, continuous "On" return path (No burst), AGC on the forward path						1570 1570nm							
							1590 1590nm							
							1610 1610nm							



All versions come standard with SC/APC optical connectors, and include the Power Supply

* Note: the series (X10) model is equipped with xPON fiber port with internal optical filter that is configured for default standard wavelengths supporting 1550 forward path RX, 1610 return TX, and PON port supporting both 1G and 10G PON wavelengths of 1270nm and 1577nm, and 1310 and 1490nm wavelengths. The node is compatible with both 1G GPON and 10G XG(S)PON

Note: ① ② Please specify levels not included in the Matrix. Note ③ sub split may be customized to customer requirement



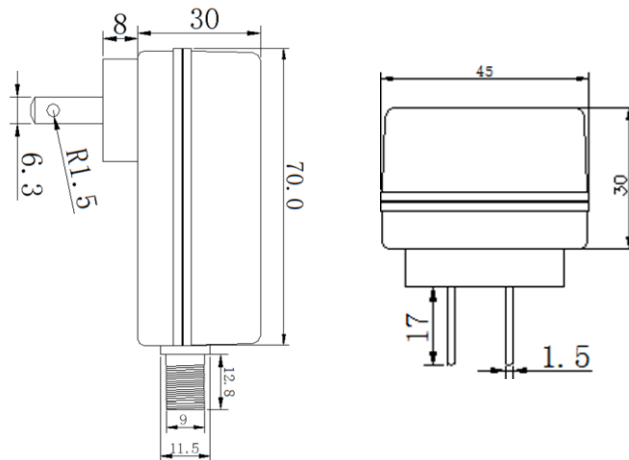
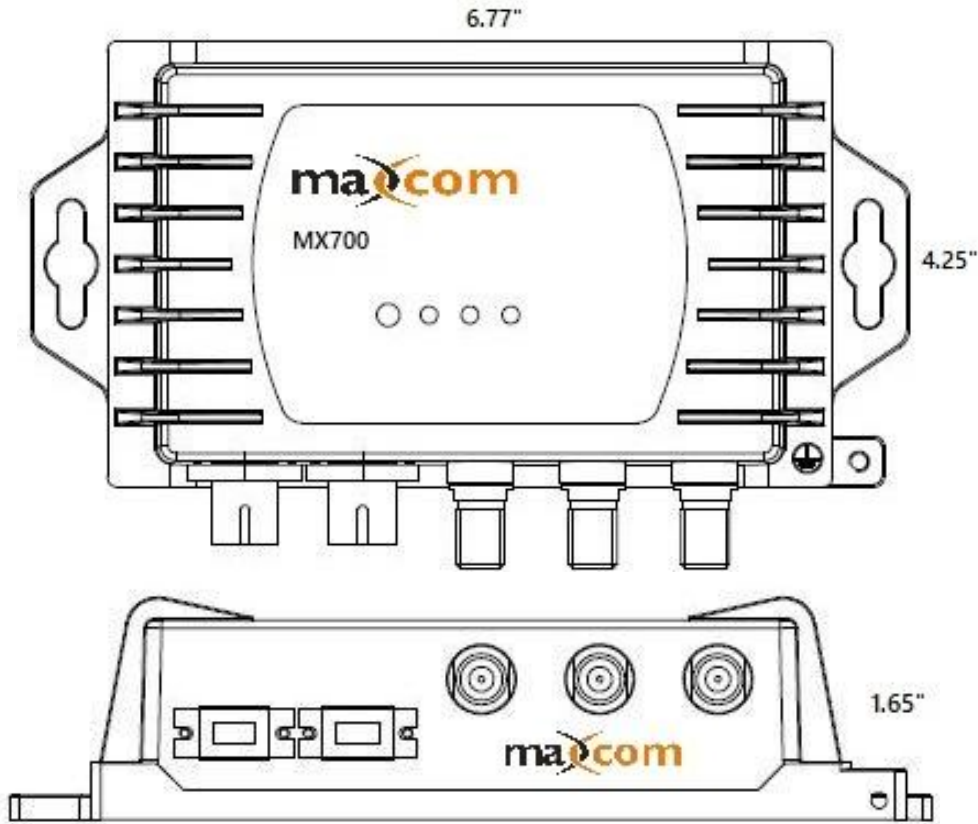

Power supply included

*North American and EURO shown

Maxcom carries a full line of Optical Products and CATV Products supporting RFoG. Contact us at 1-209-339-2333 or visit our website at www.maxcomcorp.com and let us assist with answering any questions or providing technical support.

